

ENERGIZER 390/389

ZEROMERCURY®

SILVER OXIDE



Industry Standard Dimensions

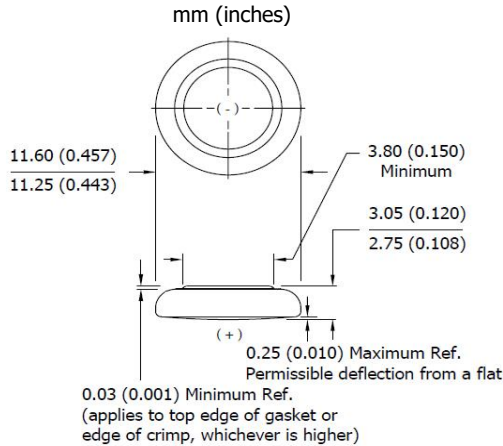

DESIGNED FOR USE ON CONTINUOUS LOW DRAIN
(HIGH PULSE ON DEMAND)

Specifications

Chemical System:	Silver Oxide (Zn/Ag ₂ O)
Designation:	ANSI-1138SO, IEC-SR54
Nominal Voltage:	1.55 Volts
Typical Capacity:	88 mAh* (to 1.2 volts)
Capacity Test:	15K ohm continuous drain at 21°C
Typical Weight:	1.35 grams (0.048 oz.)
Typical Volume:	0.32 cubic centimeters (0.019 cubic inch)
Impedance (40 Hz):	5 to 10 ohms

* Varies according to the applied load, temperature, and cutoff voltage.

Cross Section

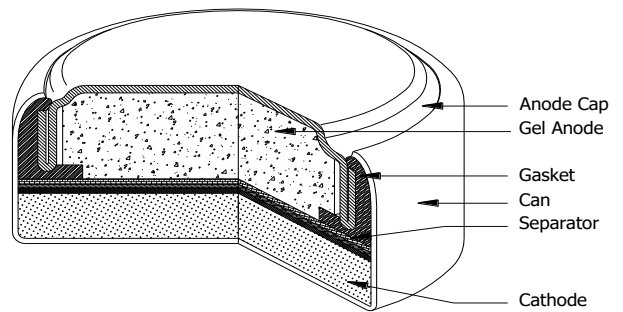

Typical Discharge Characteristics

Typical Performance at 21°C (70°F)

Schedule: Continuous
Typical Drain @1.48V:
0.099 milliamperes
Load: 15K ohm

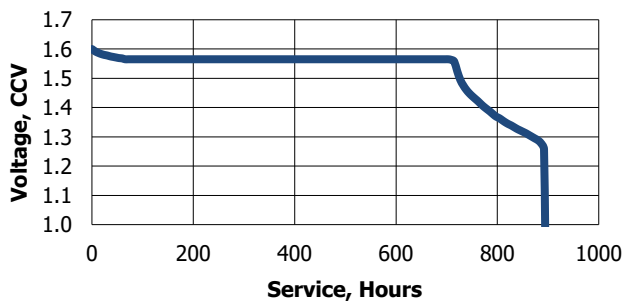

Schedule	Typical Drains at 1.48V (milliamperes)	Load (ohm)	Cutoff (hours)
Continuous	0.099	15K	892

Temperature Characteristics

Typical Performance at Low Discharge Rates

Service Effects

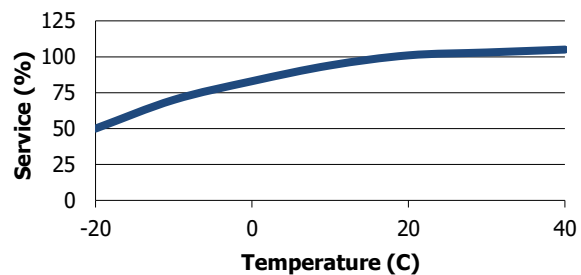

Storage Effects

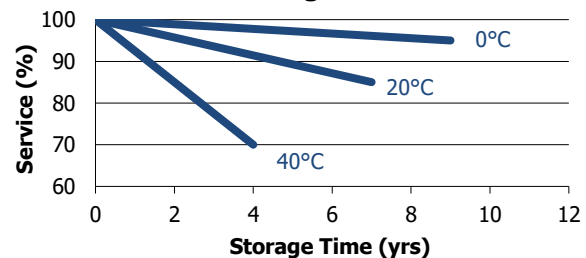

Important Notice

This datasheet contains typical information specific to products manufactured at the time of its publication.
Contents herein do not constitute a warranty and are for reference only.