



VID-TRANS10SKN

2.4GHZ WIRELESS AUDIO/VIDEO SYSTEM

OWNER'S MANUAL



CE



■ Important-Safety Precautions

This device of which operation is subject to the following two conditions

- (1) This device may not cause harmful interference, and
 - (2) This device must accept any interference received, including interference that may cause undesired operation.
- To prevent fire or shock hazard, do not expose this device to rain or moisture.
 - Do not use near a bathtub, washbowl, kitchen sink, or laundry tub, in a wet basement, or near a swimming pool.
 - To avoid electrical shock, do not open this device.
 - This device should be operated to use only the power supply included with it or provided as an accessory.
 - Do not overload wall outlets and extension cords as this can result in the risk of fire or electrical shock.
 - Do not attempt to service this device yourself. Refer servicing to qualified personnel only.

Caution: Changes or modifications not expressly approved by the Party responsible for compliance could void the user's authority to operate the equipment.

▪ **Note:**

This equipment has been tested and found to comply with the limits for a class B digital device, pursuant to Part 15 of the FCC Rules, or BZT and CE EMC directive. These limits are designed to provide reasonable protection against harmful interference in a residential installation. This equipment generates, uses and can radiate radio frequency energy, if not installed and used in accordance with the instruction, it may cause harmful interference to radio communications. However, there is no guarantee that interference will not occur in a particular installation. If this equipment does cause harmful interference to radio or television reception, which can be determined by turning the equipment off and on, the user is encouraged to try to correct the interference by one or more of the following measures:

- Reorient or relocate the receiving antenna.
- Increase the separation between the equipment and receiver.
- Connect the equipment into an outlet on a circuit different from

- that to which the receiver is connected.
- Consult the dealer or an experienced radio/TV technician for help.

A. Checking Contents of Box

Checks to make sure that all of the items shown as below are included with your 2.4 GHz Wireless Video Sender System. If something is missing, please contact your dealer as soon as possible.



1. Transmitter 2283T ×1



2. Receiver 2283R X1



3. Power adapter (230VAC to 9VDC) or (120VAC to 9VDC) DC in Jack 9V 400mA X2



4. Cable (optional) ×2
RCA to RCA connector A/V cable or RCA to SCART connector. (One for transmitter, one for receiver)



5. IR extender to connect to (optional) X1
transmitter's rear panel

6. Owner's manual ×1

B. Introduction to 2.4GHz Wireless AV Link

This sender system is a wireless audio/video sender that uses advanced wireless communication technology to deliver consistently sharp audio and video up to 100 meters away. By transmitting at a very high frequency (2.4 GHz), it avoids the crowded 900 MHz band used by many cordless telephones and other wireless audio/video transmitters. It's superior quality is due to wide-band FM rather than AM signal modulation. Circular polarized high-gain directional transmitting and receiving antennas are used to minimize interference from unwanted signals and maximize the signal range.

It also integrates an UHF remote control extender to allow you to control the audio or video source from another room using your existing remote controller.

Using sender system, you can enjoy greater convenience and security in many ways:

General Application

- Watch the movie you rent on any TV in house without moving your VCR, laser disc player or running messy cables.
- Watch cable or satellite programs on any TV in house.
- Listen to stereo-quality music from your receiver on any powered speakers inside or outside the house.
- Uses multi-receivers for broadcasting to numerous TV sets in other rooms.
- Show computer images on a remote TV. (Additional equipment required)

Safety & Security Application:

- Applies as a wireless security system.
- Monitor your sleeping baby, playing children, the elderly, or the disabled on TV using your existing camcorder.
- See who is outside the door on TV through your camera or miniature CCD camera.
- Monitors and records meeting from another room.
- And many more uses!

■ The Using Attention

1. The outlet of the power supply must have the same voltage as the local area.
2. Be sure the transmitter and the receiver were connected to the equipment correctly (e.g. Connect the transmitter to the VCR, and the receiver to the TV).
3. When switch is off from transmitter or receiver, it needs to wait for a few seconds in order to restart again.
4. Adjust antenna plate for least interference. (Adjustment cannot rotate more than $\pm 180^\circ$).
5. In most situations, one set of equipment has a better feature within 100 meter. When two equipment or more is used at the same time, used different channels. But a transmitter can be used with several receivers at the same time.
6. The channel selectors allow you to choose the channel for best feature and least interference.
7. When the equipment is operating, please do not use a microwave oven near by.
8. The remote control should face to the receiver (e.g. 2283R) IR remote control window, and the transmitter (e.g.2283T) IR remote control window (or IR extender) should face to the source A/V equipment. The IR remote has to be within the standard distance.

C. Panel Controls and Features of Duplex Function Type

The following illustrations show the names of each component, button and switch connectors on the transmitter and receiver. (e.g.2283T/R)

FRONT VIEW FOR TRANSMITTER AND RECEIVER

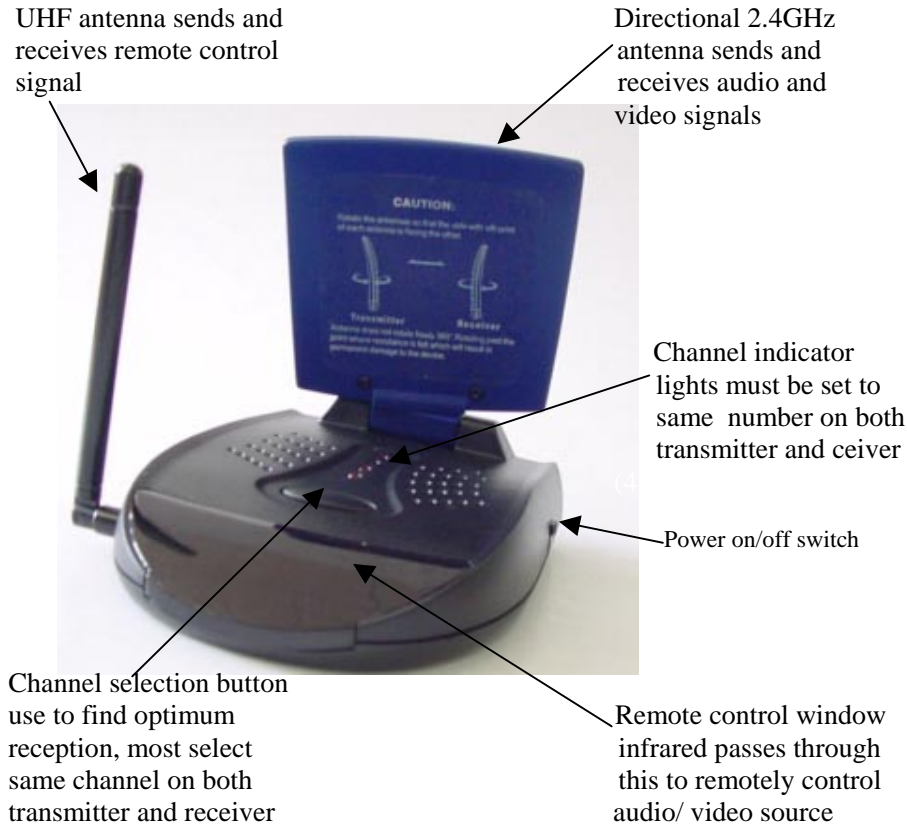

REAR VIEW FOR TRANSMITTER

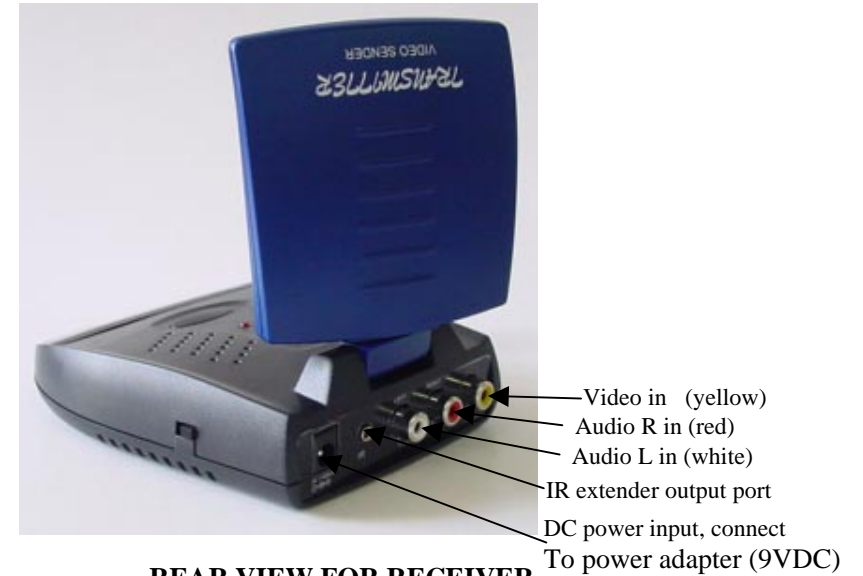

REAR VIEW FOR RECEIVER

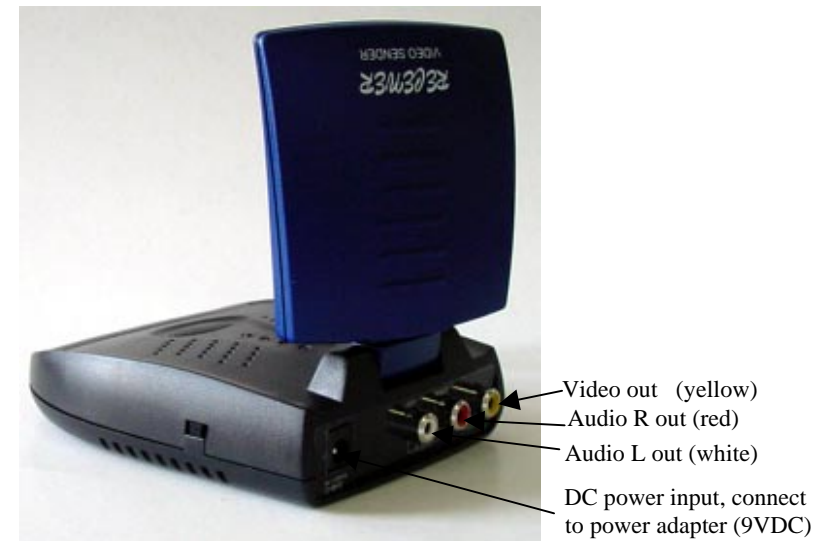

D. Setting Up 2.4GHz wireless AV Link

To enjoy wireless video and audio, just connect the transmitter (2283T and all the others) to whatever audio/video source you want to enjoy from another location, and connect the receiver (2283R and all the others) to the TV, monitor or powered speakers in that other location.

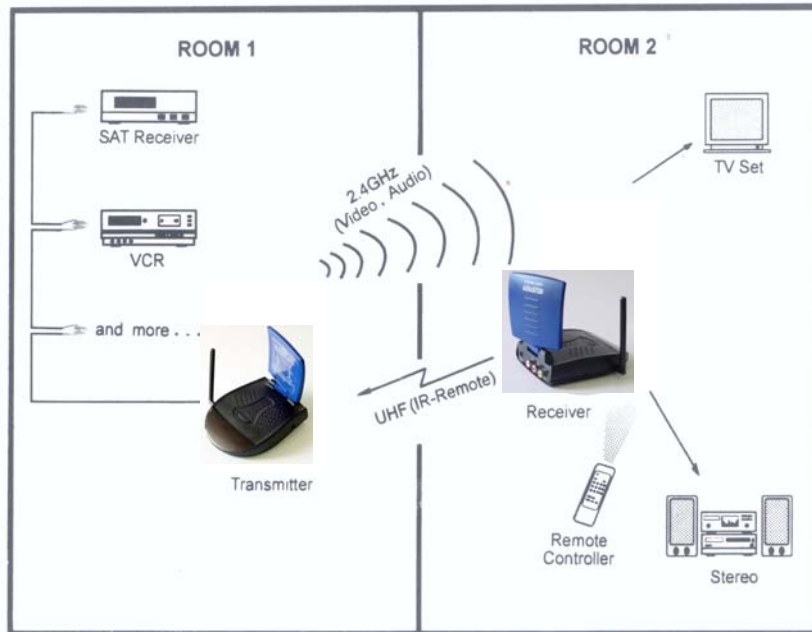

Video sources:

VCR
Set-top box (with A/V output)
Satellite Receiver
Camcorder or Miniature CCD Camera
Cable
Digital decoder
DVD

Audio sources:

Compact Disk player or Changer
Stereo Receiver
Cassette Deck
Laser Disc Player

Make sure the ON/OFF switch is in the OFF position before connection.

How To Transmit Audio/Video from Your VCR

1. Connect one set of audio/video (A/V) cables (RCA or SCART cable) to the A/V jack of the transmitter (2283T) and to the A/V output jacks (RCA or SCART connector) on the back of your VCR. If you use 2283T/R, Be sure the yellow, red and white plugs match the yellow, red and white jacks on both the VCR and the transmitter. If the VCR has only one output for audio (mono sound only), connect the white plug to that single audio output and to transmitter's AUDIO LEFT jack.
2. Plug one end of the power adapter into the back of the transmitter and the other end into any 230-volt wall outlet (or 120-volt). Use only the adapter provided.
3. If your VCR has only one set of A/V output jacks and you want to use it with a nearby TV, connect 75ohm RF coaxial cable from the modulator signal OUT port on your VCR to the RF IN port on your TV. (Note: In order to also view cable programs on that TV, connect your incoming cable TV source to the IN port of the VCR.)
4. Locate and orient the transmitter according to the section of this manual titled "Orienting Units for Optimum Performance" for best performance of transmitter.

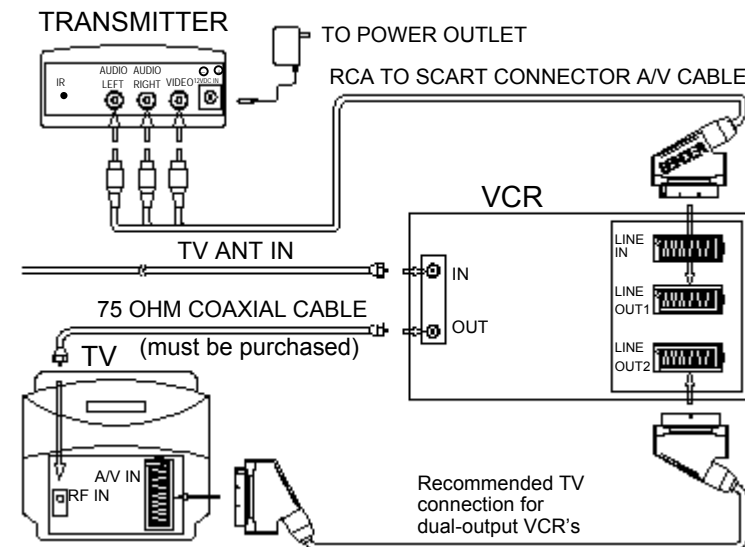

■ How To Transmit Audio/Video from Your Satellite Receiver

You can transmit audio/video either directly from your satellite receiver, or by connecting them to your VCR. To transmit directly from your satellite receiver, follow the instructions below.

1. Connect one set of audio/video (A/V) cables (RCA or SCART cable) to the A/V jacks of the transmitter (2283T) and to the audio/video OUT jacks (RCA or SCART connector) of the satellite receiver or laser disc player. If you use 2283T/R, Be sure the yellow, red and white plugs match the yellow, red and white jacks on both the satellite receiver/laser disc player and the transmitter.
2. Plug one end of the power adapter into the back of the transmitter and the other end into any 230-volt wall outlet (or 120-volt). Use only the adapter provided.
3. If your satellite receiver or laser disc player has only one set of A/V output (RCA or SCART connector) jacks, in this case, please connect 75ohm RF coaxial cable from satellite receiver's modulator output port to TV RF input terminal.
4. Locate and orient the transmitter according to the section of this manual titled "Orienting Units for Optimum Performance" for best performance of transmitter.

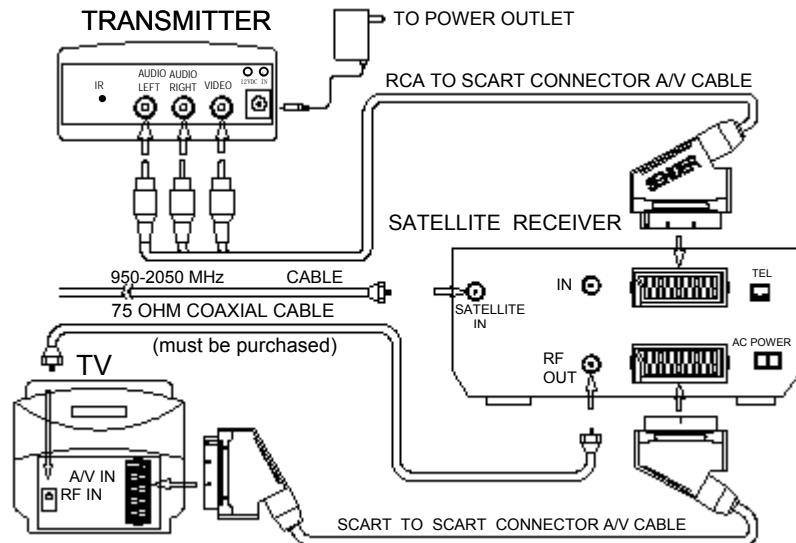

■ How To Receive Wireless Audio/Video Signals on Your TV

There are two ways to receive wireless audio/video signals on your remote TV (TV in another location such as in bedroom, kitchen).

- Connect the receiver directly to the remote TV.
- Connect the receiver to a VCR, which is then connected to the TV.

If your TV has picture-in-picture capabilities, you can view any image transmitted by sender, such as your sleeping baby, in a small inset picture while enjoying other programming on the rest of the screen. Consult the owner's manual of your TV for instructions on using these capabilities.

Connecting Receiver Directly to Remote TV

If your TV has A/V jacks, connect one set of A/V cables (RCA or SCART cable) to the TV's A/V jacks and to the A/V output jacks on the receiver (2283R). If you use 2283T/R, Be sure the yellow, red and white plugs match the yellow, red and white jacks on both the TV and the receiver.

If the TV has only a single jack for audio input, connect the white plug to that jack.

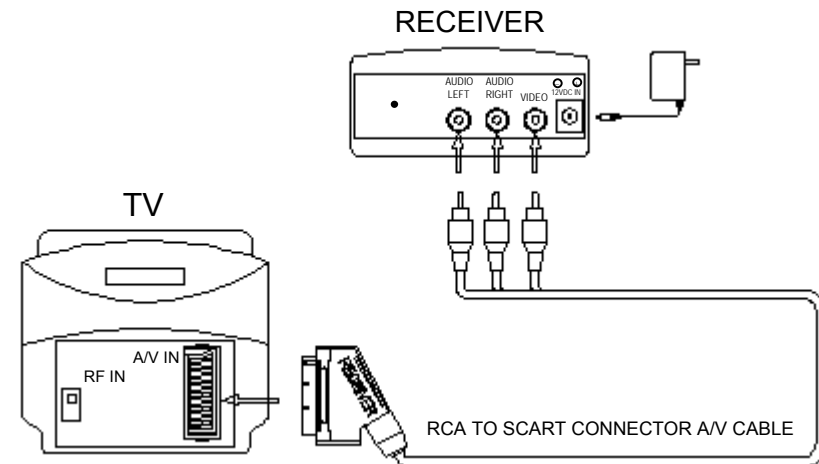

■ Connecting Receiver to Remote TV through VCR

This setup enables you to record transmitted audio and video on your remote VCR and also enjoy the picture and sound on a remote TV at the same time.

1. Connect one set of audio/video (A/V) cables to the A/V output jacks of the receiver (2283R) and to the A/V input jacks on your VCR
If you use 2283T/R, Be sure the yellow, red and white plugs match the yellow, red and white jacks on both the receiver and the VCR. If the VCR has only a single jack for audio input, connect the white plug to it.
2. If your TV has A/V input jacks, connect another set of A/V cables to the TV's A/V input jacks and to the A/V output jacks on your VCR.
3. If your TV does not have any A/V input jacks, please connect a 75ohm coaxial cable from the TV's antenna in (or RF in) to VCR's modulator output.

This feature is optional

4. Plug one end of the sender power adapter into the back of the receiver and the other end into any 230-volt (or 120 volt) wall outlet. Use only the adapter provided.
5. Locate and orient the receiver to best video and sound quality please according to the section of this manual titled "Orienting Units for optimum Performance".

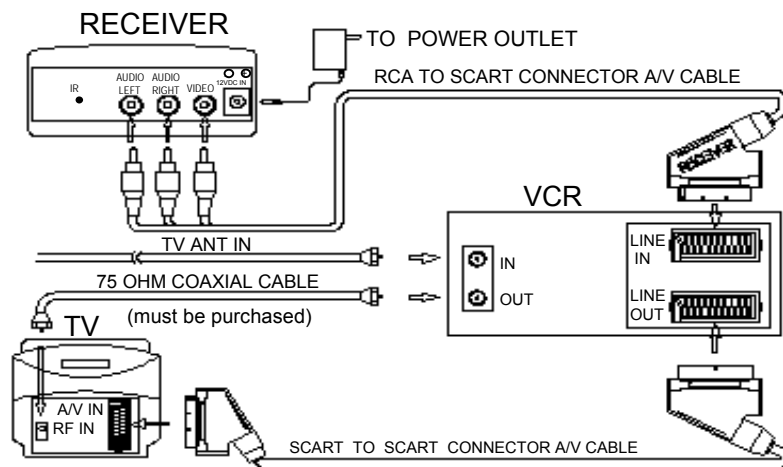

E. Orienting Units for Optimum Performance

This sender system should be placed on a flat, stable surface to prevent damage to it from falling.

For optimum performance, both the audio/video and remote control antennas should be carefully oriented as described below. In addition, to use the remote extension feature, the transmitter itself must be specially oriented so it can relay the converted remote control signal back to the audio/video source (see following section titled "Using The Remote Control extension Feature"). For maximum operating range, try to minimize the number of obstacles (e.g. your TV or other electronics, large furniture) where between the transmitter and receiver units.

Orienting the Audio/Video Antennas

Sender broadcast their high-quality audio and video using directional antennas, which must be oriented in certain configurations for best results. The antennas have been designed to pivot and rotate in-almost any direction.

In most situations, the flat-pitted face of the antennas on both the transmitter and receiver should be facing one another and perpendicular (at a right angle) to an imaginary line drawn between the two units. Three examples are shown Fig-1, Fig-2 and Fig-3. Since all homes are different, for optimum reception, additional slight pivots or rotations may be necessary. If the transmitter and receiver are less than 10 feet apart, suggest keeping the antennas flat in their casings since the distance is so short.

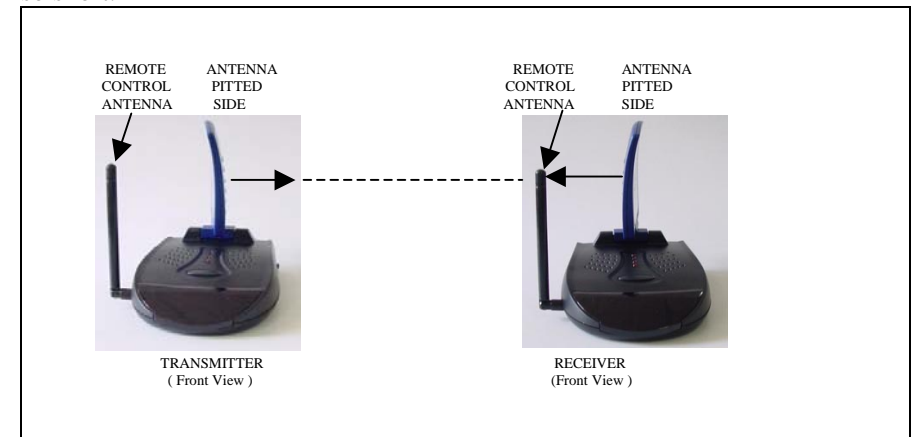

Fig-1: How to orienting the 2.4GHz audio and video antennas.

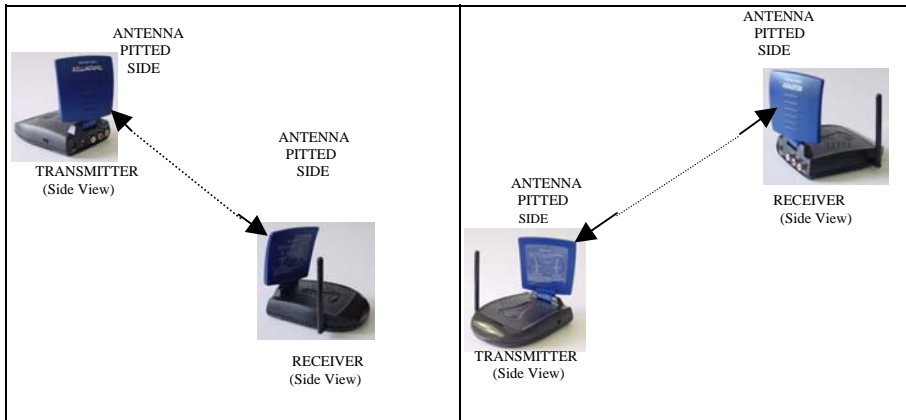

Fig-2

Fig-3

Orienting the Remote Control Antennas

In order to obtain optimum performance of the remote control extender, the remote control antennas should also be oriented at a right angle to an imaginary line drawn between the transmitter and receiver units.



ANTENNA

If your remote control extender is not working satisfactorily, rotating the remote control so that it is still perpendicular to the path between the units (see Fig-4)

If you notice improved performance, keep this orientation. Rotating the antenna on both units should have no effect.

Fig-4: How to orienting the remote control antenna

F. Using the Remote Control Feature

This sender system not only allows you to send crisp audio/video from one area to another, it also gives you the ability to control the source using your existing remote control device. It converts the infrared (IR) signal emitted by your remote control to a radio frequency (RF) signal in UHF band at the receiver (e.g.2283R) and sends it back to the transmitter (e.g.2283T) where the RF signal is converted back to the original IR signal and beamed to the audio/video source.

There are two ways to get your source A/V equipment to be controlled by using existing remote control through remote control feature:

- 1.To orient the transmitter unit, face to face the source A/V equipment, this would allow the converted IR signal, which from transmitter IR remote control window be able to send to the source A/V equipment(s) front panel.
2. Simply connect an IR extender from transmitter and locate this IR extender near the source A/V equipment from panel.

Sometimes, it may be difficult or even impossible to orient the transmitter unit such that it can be "seen" (means face-to-face) by the A/V equipment you wish to control. Perhaps there is no good surface that allows for this or perhaps you wish to remotely control A/V equipment in different locations without re-orienting the transmitter. So, in this case, to use in extender will be more convenient.

■ How to Use the IR Extender Accessory

The IR extender connects to the transmitter through its own special connector plug. The extender emits an IR signal can control your A/V equipment with the remote signal. To use the IR extender, follow the instructions below:

- (1) Plug the IR extender into the 2.5mm phone jack of transmitter's rear panel.
- (2) Connect the infrared cable at the left of the transmitter and put one of the LED on the infrared receiver of the A/V source. You have 3 more LED's at you disposal to control 3 additional A/V appliances. More the LED in order to find the most appropriate spot.

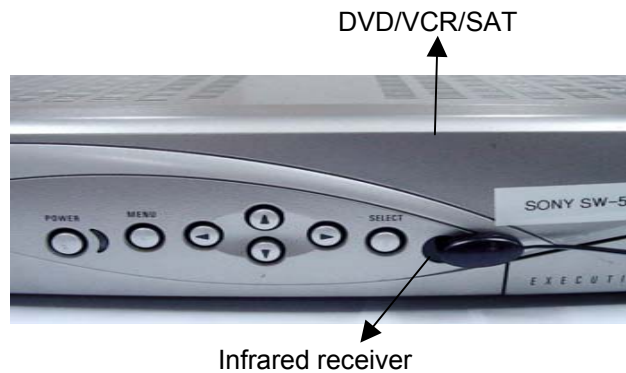

Fig-5

- (3) Position the receiver so that your remote control signal can strike the IR window on the bottom front of the unit. To use your remote control, point it at the front of the receiver.

G. Troubleshooting, Care and maintenance

Please read this owner's manual carefully and follow the steps described in it. If you still have difficulties, consult the following table. It will guide you though the most common problems and their solutions.

Problem	Possible solutions
No picture or sound	<ul style="list-style-type: none"> • Check all cable connections. • Make sure power plugs are pushed all the way in. • Check power switches on the remote TV and Video source. (VCR, laser disc player, satellite receiver, ect.) • Check the power on/off switches on the transmitter and receiver.
Interference: Noisy picture or audio	<ul style="list-style-type: none"> • Adjust receiver and transmitter antenna orientation. (see section on "Orienting Units for Optimum Performance" in this manual) • Select a different channel by pushing the channel selector button on both transmitter and receiver so that the channels match. • If using a microwave oven, turn it off. • Remove microwave oven from path between transmitter and receiver.
Remote control extender does not work	<ul style="list-style-type: none"> • Check the path between the transmitter and the audio/video source and clear any obstructions. • Check to see if the IR window on the bottom front of the transmitter is blocked. • Make sure IR extender is properly rotated in the A/V equipment you wish to control. (see section on "Using the Remote Control Feature" in this manual) • Adjust remote control antennas. (see section on "Orienting Units for Optimum Performance" in this manual)

Note: Clean the outside plastic packaging with a soft cloth lightly moistened with mild soap and water. Never use any abrasive scouring powder or solvent.

H. Specifications

Transmitter:

Operating Frequency Band	2.400GHz~2.4835GHz
Output Level	90 dB μ V/m at 3 meters
Modulation	FM (video and audio)
Channel	PLL frequency synthesizer
Video Input Level	1V p-p @ 75 ohm
Audio Input Level	1V p-p @ 600 ohm (STEREO)
Input Port (OPTIONAL)	A/V jack-RCA line jack, SCART socket
Antenna	Directional flat antenna
IR-remote IR output	940nm with ON/OFF keying
Power consumption	9VDC, 230mA
Dimension	120mm×88mm×34mm
Weight	180g

Receiver:

Operating Frequency Band	2.400GHz~2.4835GHz
Noise Figure	3.5dB
Channel	PLL frequency synthesizer
Video Output Level	1V p-p @ 75 ohm
Audio Output Level	1V p-p @ 600 ohm (STEREO)
Output Port (OPTIONAL)	A/V jack-RCA line jack, SCART socket
Antenna	Directional flat antenna
IR-remote Relay	
Transmit Frequency	433.92 MHz
Infrared freq. Input	35KHz~41 KHz
Power consumption	9 VDC, 230mA
Dimension	120mm×88mm×34mm
Weight	210g

System:

Operational range	up to 100 meter	(line of sight)
Remote control range	up to 50 meter	(line of sight)

•All specification subject to change without notice

GENERAL INFORMATION:

MANUFACTURER/IMPORTER

Nedis B.V.
De Tweeling 28
5215MC 's-Hertogenbosch
The Netherlands
Tel.: 0031 73 5991055
Fax.: 0031 73 5999699
Email: info@nedis.com
WWW: www.nedis.com



ET91R-12-050
(report No.)

DECLARATION OF CONFORMITY

We, Nedis B.V.
(manufacturer's name)

De Tweeling 28, 5215MC, 's-Hertogenbosch, The Netherlands
(manufacturer's address)

Declare under our responsibility that the radio product:

KONIG VID-TRANS10SKN
(name) (type or model)

2.4Ghz Transmission / Reception System
(product description)

to which this declaration relates is in conformity with the following standards:

Radio: EN 300 220-3 (2000-09); EN 300-440 (1999-04)
EMC: EN 301 489
Safety: EN 60065: 1998
(title, number and date of issue of the standards)

following the provisions of 1999/5/EC (R&TTE Directive).

's-Hertogenbosch, 13-07-2003
(place and date)

T. Boer
General Director
(signature, name and function)

